

# **PC Series III Product Coolers**

## **Operating and Installation Manual**

# TABLE OF CONTENTS

<b>1</b>	<b>RECEIPT OF EQUIPMENT</b>	<b>3</b>
1.1	INSPECTION	3
1.2	LOSS OF GAS HOLDING CHARGE	3
<b>2</b>	<b>ASSEMBLY OF COMPONENTS</b>	<b>3</b>
2.1	SHIPPED LOOSE PARTS	3
2.2	FAN GUARD OR LONG THROW ADAPTER	3
2.3	WATER DEFROST SPLASH GUARD	3
2.4	DIELECTRIC FLANGE UNION	3
2.5	REFRIGERANT DISTRIBUTOR NOZZLE	4
2.6	EXPANSION VALVE (OPTIONAL ITEM)	4
<b>3</b>	<b>RIGGING INSTRUCTIONS</b>	<b>4</b>
<b>4</b>	<b>UNIT LOCATION AND MOUNTING</b>	<b>4</b>
4.1	UNIT LOCATION	4
4.2	MOUNTING	5
<b>5</b>	<b>REFRIGERANT WARNING</b>	<b>5</b>
<b>6</b>	<b>PIPING INSTALLATION</b>	<b>5</b>
6.1	DRAIN LINE	5
6.2	REFRIGERATION PIPING	6
6.3	HOT GAS INTERPIPING	7
6.4	EVACUATION AND LEAK TEST	7
6.5	DXA AND SUCTION ACCUMULATORS	7
<b>7</b>	<b>ELECTRICAL</b>	<b>7</b>
7.1	FIELD WIRING	7
7.2	ELECTRICAL DATA	8
7.3	SUGGESTED NO DEFROST REQUIREMENT SEQUENCE OF OPERATION	12
7.4	SUGGESTED AIR DEFROST SEQUENCE OF OPERATION	12
7.5	SUGGESTED ELECTRIC DEFROST SEQUENCE OF OPERATION	12
7.6	SUGGESTED HOT GAS DEFROST SEQUENCE OF OPERATION	12
7.7	SUGGESTED WATER DEFROST SEQUENCE OF OPERATION	13
<b>8</b>	<b>OPERATION</b>	<b>13</b>
8.1	PRE-START UP	13
8.2	OPERATION CHECKOUT	14
<b>9</b>	<b>MAINTENANCE</b>	<b>15</b>
9.1	DRAIN PAN	15
9.2	COIL AND CABINET	15
9.3	FAN GUARD OR LONG THROW ADAPTER REPLACEMENT	15
9.4	FAN REPLACEMENT	15
9.5	PC TYPE UNIT MOTOR REPLACEMENT	16
9.6	45° DOWN DISCHARGE OR PH TYPE UNIT MOTOR REPLACEMENT	17
9.7	ELECTRIC DEFROST HEATERS	17
9.8	WATER DEFROST DISTRIBUTION PAN	17
<b>10</b>	<b>REPLACEMENT PARTS LIST</b>	<b>18</b>
<b>11</b>	<b>MAINTENANCE DATA</b>	<b>24</b>

## **TABLES**

<i>Table 1 60 HZ MOTOR AMPS (approximate)</i> .....	8
<i>Table 2 50 HZ MOTOR AMPS (approximate)</i> .....	8
<i>Table 3 COIL (ED) HEATER AMPS</i> .....	10
<i>Table 4 COIL AND DRAIN PAN (EDL) HEATER AMPS</i> .....	11
<i>Table 5 STANDARD MOTOR, FAN, BUSHING (30" DIA. FAN UNITS)</i> .....	18
<i>Table 6 STANDARD MOTOR, FAN, BUSHING (36" DIA. FAN UNITS)</i> .....	18
<i>Table 7 STANDARD MOTOR, FAN, BUSHING (42" DIA. FAN UNITS)</i> .....	19
<i>Table 8 FAN GUARDS &amp; LONG THROW ADAPTERS</i> .....	19
<i>Table 9 230 &amp; 460 VOLT ELECTRIC DEFROST HEATERS</i> .....	20
<i>Table 10 575 &amp; 380 VOLT ELECTRIC DEFROST HEATERS</i> .....	21
<i>Table 11 REPLACEMENT DRAIN PANS</i> .....	22
<i>Table 11 REPLACEMENT DRAIN PANS (continued)</i> .....	23

## **FIGURES**

<i>Figure 1 Drain Line</i> .....	6
<i>Figure 2 Pipe Joining</i> .....	6
<i>Figure 3 Aluminum Flange Assembly</i> .....	8
<i>Figure 4 Electric Defrost Wiring 230/3/60</i> .....	9
<i>Figure 5 Electric Defrost Wiring 460-575/3/60 or 380/3/50</i> .....	9

# **1 RECEIPT OF EQUIPMENT**

## **1.1 INSPECTION**

All equipment should be carefully checked for damage or shortages as soon as it is received. Each shipment should be carefully checked against the bill of lading. For shipments with more than one unit on the truck, the Fan Guard(s) are shipped loose from the evaporator. If optional Long Throw Adapters have been ordered, the adapter(s) are shipped loose from the evaporator. When receiving a shipment make sure either the Fan Guard(s) or Long Throw Adapter(s) is(are) delivered with the unit. If any damage or shortage is evident, a notation must be made on the delivery receipt before it is signed and a claim should then be filed against the freight carrier. Inspection and claims are the responsibility of the recipient.

## **1.2 LOSS OF GAS HOLDING CHARGE**

Each copper, steel, and stainless steel tube PC Series III unit is leak tested, evacuated to remove moisture and then shipped with a gas holding charge. Absence of this charge may indicate a leak has developed in transit. The system should not be charged with refrigerant until it is verified that there is no leak, or the source of the leak is located. If the unit contains aluminum tubes or flanged refrigerant connections, the unit is leak tested and evacuated but a gas holding charge is not provided.

# **2 ASSEMBLY OF COMPONENTS**

## **2.1 SHIPPED LOOSE PARTS**

Fan Guard(s) or Long Throw Adapter(s) (may be factory mounted)

Water Defrost Splash Guards with required bolts and nuts (may be factory mounted)

Dielectric Flange Union with required bolts, nuts, and gaskets (if the coil contains Aluminum tubes)

Special or Extended Legs

Thermal Expansion Valve (may be factory mounted).

## **2.2 FAN GUARD OR LONG THROW ADAPTER**

If the Fan Guard(s) or Long Throw Adapter(s) is(are) shipped loose it(they) should be mounted on the unit before the unit is installed. The evaporator fan cabinet contains through-bolts with the threaded end pointing out away from the fan cabinet. The bolts have two ½” nuts, flat washers, and a lock washer on them. Remove the outer most nut, lock washer, and one flat washer. Place the Fan Guard or Long Throw Adapter on the bolts braced against the remaining flat washer. While holding the guard or adapter with one hand place the flat washers, then the lock washers, and then thread the nuts on the top two bolts to hold the guard or adapter in place. Then place the remaining washers on and thread the other two nuts on the bottom two bolts. Tighten with a wrench.

## **2.3 WATER DEFROST SPLASH GUARD**

If the water defrost splash guard is shipped loose, align the holes in the guard to the holes on the bottom horizontal support angle on the air inlet side of the evaporator. Use the bolts and nuts provided with the splash guard to hold it in place.

## **2.4 DIELECTRIC FLANGE UNION**

Aluminum tube evaporators have aluminum flanged refrigerant connections. A dielectric flange union to attach steel pipe to the aluminum evaporator flange is provided in a separate box. The box should contain dielectric bolt gaskets, bolts, nuts, flange gasket, and mating steel socketweld flange. To avoid material damage during assembly, preweld a length of refrigerant pipe to the steel flange before assembly to the aluminum flange. See Section 6.2 for the aluminum to steel flange assembly drawing.

## 2.5 REFRIGERANT DISTRIBUTOR NOZZLE

For a direct expansion system, the PC Series III units already have the distributor nozzle installed. As a check, see that the nozzle is in the distributor, or the auxiliary hot gas tee for direct expansion halocarbon with hot gas defrost, before installing the thermal expansion valve to the distributor or auxiliary hot gas tee.

## 2.6 EXPANSION VALVE (Optional Item)

Before hanging a unit with a direct expansion design, install the expansion valve and connect the equalizer tube. The expansion valve should be installed directly to the distributor body or as close as possible with no elbows or bends. **Steel expansion valves for ammonia requires the removal of the discharge tube.** Locate the expansion valve bulb on a horizontal length of suction line as close to the suction header as possible. Position the bulb in a 3, 4, 8, or 9 o'clock position. **Do not position the bulb on the top or the bottom of the pipe.** Clamp the bulb down flush and tight against the pipe and insulate. Never locate the bulb on a trap or downstream from a trap.

Expansion valves are NOT adjusted at the factory prior to shipment. It is important that the operation of the expansion valve be checked after the system has balanced out at the desired room temperature. If the coil is being starved it is necessary to reduce the superheat setting of the valve by turning the adjusting stem counter-clockwise. If the superheat is too low it is necessary to increase the superheat setting of the valve by turning the adjusting stem clockwise. It is recommended that for a 10°F to 12°F T.D. system, the valve be adjusted to maintain 5°F to 6°F of superheat.

## 3 RIGGING INSTRUCTIONS

A PC Series III unit tends to be a long and heavy object with about 2/3 of the weight contained in the coil element at the rear of the unit. Jobsite requirements will affect the method of moving and lifting the unit into place. Carefully consider the support that is required to lift and move the unit. Under no circumstances should the shipping skid be used for lifting the unit. To ensure that the unit is not bowed or damaged when being lifted into place from above, all leg or hanger points should be used. If the unit is being lifted into place from underneath, a level support directly under all of the shipping legs is required to adequately steady the unit as it is lifted to the hanger rods.

## 4 UNIT LOCATION AND MOUNTING

### 4.1 UNIT LOCATION

Unit must be located to provide good air circulation to all areas. The unit should be positioned to blow away from walls and directed down an aisle, over product, or into product as the room design is specified. For best performance it is desirable to arrange the air discharge toward the door of the room to minimize the entrance of warm moist air when the door is open. If the distance between the PC unit and a dock door is within the longest third of the unit standard air throw distance, long throw adapters should be considered to keep air velocity up in the door area. Light fixtures, shelving, ceiling structures, and product boxes must be located so that they do not block the air intake or air discharge from the unit.

#### **IMPORTANT:**

**The coil face must be located away from a wall a minimum distance equal to the height of the coil to assure unrestricted air intake.**

On all PC Series III units a space should be provided for the possible future replacement of the electric defrost heaters if heaters have been furnished. Tables 3 & 4 specify the recommended access dimensions that are needed to remove the heater rods on one or both ends of the unit.

## 4.2 MOUNTING

The PC Series III units should be suspended with 3/4" diameter threaded STEEL hanger rods. Do not use nylon threaded rods. Rods should have double nuts on the top and bottom. Adequate support must be provided to hold the weight of the unit. Refer to the unit drawing supplied with the unit or the PC Series III catalog for the approximate unit weight and hanger locations. All hanger holes should be used to support the unit. **Do not temporarily support a unit using less than all hanger or shipping leg holes.** The shipping support legs can be removed after the unit is hung. If the PC Series III unit is floor or platform mounted, anchor the unit through the holes in the pads at the bottom of each support leg. See unit drawing for mounting hole locations. If the refrigeration system is direct expansion, the distributor orifice and expansion valve should be in place before the unit is hung. See Sections 6.4 & 6.5.

The unit must be level in all directions to insure proper drainage of the condensate drain pan. Suspended units must have sufficient clearance above for cleaning the top of the unit and repairing the Water Defrost assemblies, if provided.

## 5 REFRIGERANT WARNING

The use of any refrigerant can be dangerous under certain conditions. Where people or product can be exposed to hazardous conditions, daily inspections should be made for the detection of any defect or malfunction that could cause the escape of the refrigerant and cause harm. In the case of halocarbon refrigerants, electronic detection devices are available for sensing the presence of such refrigerants in the atmosphere.

**Ammonia** is a "self-alarmed" gas with its strong odor but detection devices are strongly recommended. People and product are a concern based on the concentration levels (ppm) of ammonia along with OSHA and EPA regulations. An ammonia gas detection device connected to an external alarm system to warn that a leak is occurring is recommended. Refer to local codes and Fire Department for additional local regulations.

Only experienced, qualified personnel should install, operate, and maintain detection and alarm equipment.

## 6 PIPING INSTALLATION

### 6.1 DRAIN LINE

The drain line should be as short and as steeply pitched as possible with a minimum of 1/4" drop per running foot. The drain line should be the same size, or larger, as the drain pan connection. A drain line trap should be installed to prevent warm moist air from migrating through the drain line. The trap should be located in the warmest and/or lowest section of the piping to avoid freezing and provide sufficient liquid head for flow through the trap. If the temperature surrounding the drain line is below freezing (32°F) it must be wrapped with a drain line heater and insulation. Be sure to also wrap the drain pan coupling. The drain line heater should be energized continuously, but to avoid the possibility of overheating, heat tape manufacturers recommend a thermostat be installed. Be sure to follow the manufacturer's recommendations. The drain line trap should be outside of the freezing space. See Figure 1.

A union at the drain pan connection is recommended for future servicing. The union should be located just outside the edge of the drain pan so that when the pan is lowered for cleaning or repair the drain line run is not in the way. Use two wrenches when tightening to prevent the drain fitting from twisting and damaging the drain pan. See Figure 2.

Long runs of drain line, i.e. more than a few feet, should be supported by hangers to avoid damage to the drain pan. For cleaning and inspecting the drain, tees with plugs are recommended instead of elbows.

**Figure 1 Drain Line**

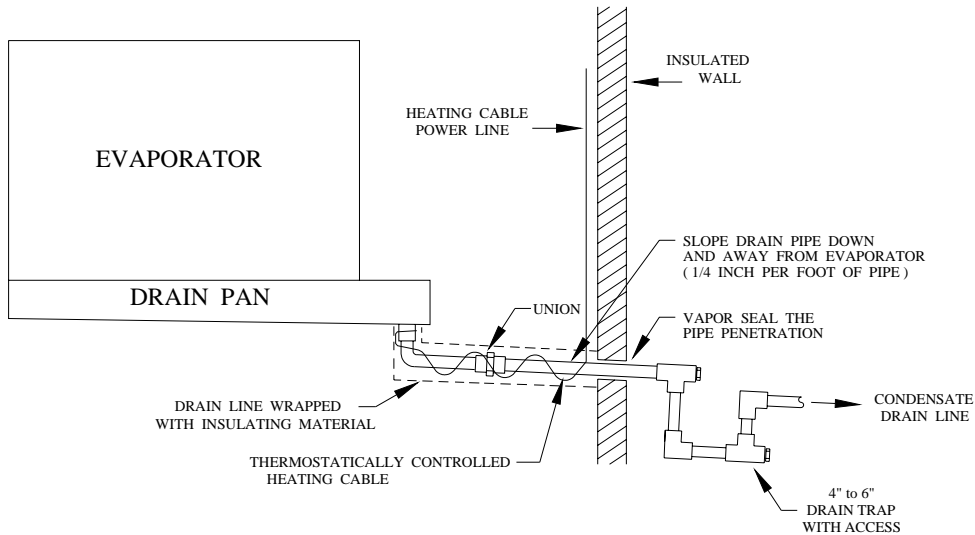

**Figure 2 Pipe Joining**

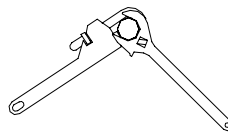

## 6.2 REFRIGERATION PIPING

Installation design must conform to all local and national codes, laws and regulations applying to the site of installation. In addition, safety codes for mechanical refrigeration, IIR-2, ANSI/ASHRAE Std. 15, and ASME B31.5, should be followed as a guide to safe installation and operation practice.

Refrigerant line sizes, piping support, and piping techniques should be obtained from published recognized refrigeration standards. Under no circumstances should the refrigerant connection size of the unit be used as the basis for sizing the lines.

### **IMPORTANT:**

**The PC Series III units have not been designed to carry the weight of any external piping or valves. Improper support of external piping and valves may result in unit breakage and refrigerant spillage.**

The horizontal suction line should slope away from the unit. Vertical suction risers on halocarbon systems require a properly sized “P” trap at the foot of the riser for proper oil return, and thermostatic expansion valve operation.

Aluminum tube units will have aluminum flanged refrigeration connections. Steel Companion flanges with bolts, nuts, and gaskets are shipped loose with the unit. Weld the steel flange to the refrigeration

pipng or a long stub before bolting to the aluminum flange to avoid heat damage to the aluminum flange and gaskets. See Figure 3 for an assembled view of the aluminum/steel connection.

**Figure 3 Aluminum Flange Assembly**

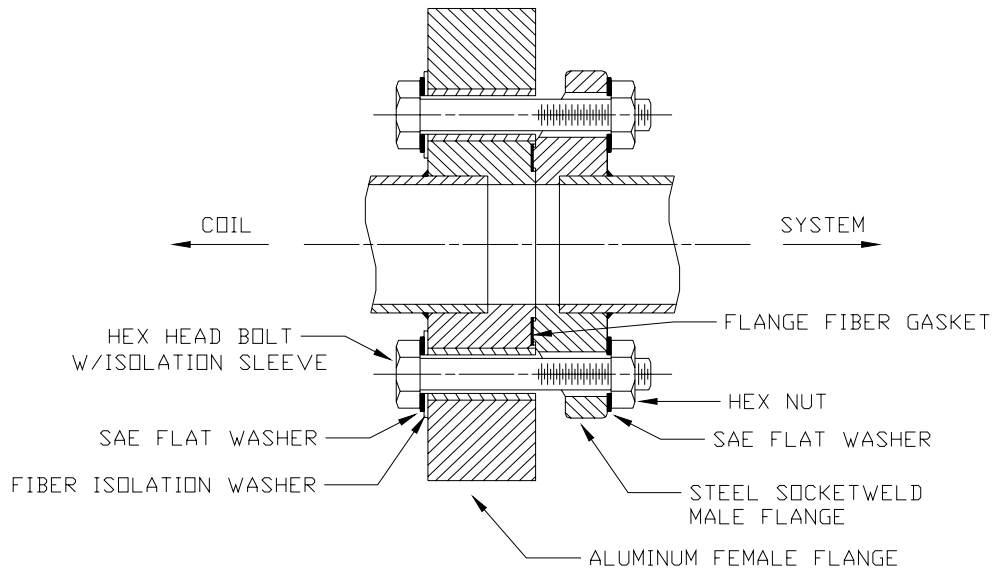

### 6.3 HOT GAS INTERPIPING

If the unit was ordered with hot gas defrost the drawing shipped with the unit will contain the piping connection locations for the hot gas inlet and the condensate relief.

### 6.4 EVACUATION AND LEAK TEST

When all refrigeration connections have been completed, the entire system must be tested for leaks and then evacuated.

### 6.5 DXA AND SUCTION ACCUMULATORS

Do not use units with Direct Expansion Ammonia (DXA) feed below 0°F evaporating temperatures unless the compressor system is designed and protected to handle the overfed liquid by use of a suction accumulator.

## 7 ELECTRICAL

### FOR SAFETY BEFORE SERVICING:

If the PC Series III unit is equipped with an electrical power disconnect switch make sure the switch is in the “OFF” position before working on the unit, preferably locked out in this position.

### 7.1 FIELD WIRING

Field wiring should comply with NEC and local codes. The power supply voltage, phase and frequency must match what is shown on the unit data plate. Wire each motor so that the fan rotation is counter-clockwise.



Wiring for a unit with Air, Hot Gas, or Water Defrost, without a Krack mounted electrical panel, requires power to the fan motor terminal blocks only. The fan motor terminal blocks are located in the electrical panel on the refrigerant connection end of the unit. If the unit is supplied with Electric Defrost, but no control panel, wiring will be required to the mounted terminal blocks in the electrical enclosure for both the motor(s) and defrost heaters. See Figure 4 for typical unit wiring with 230/3/60 power or Figure 5 for 460/3/60, 575/3/60 or 380/3/50 power. If a Krack mounted control panel is provided, wiring to only one set of terminal blocks is required. See wiring diagram supplied with unit.

A motor in a cold room may draw greater than nameplate amperage due to denser, colder air flowing through the unit. For a motor requiring external overload protection, measure motor amps after pulldown and select correct motor overloads for the measured amperage. Also compensate for the variance in ambients between motor and overload locations. Motor overload protection is recommended for all phase legs. All wiring must be in accordance with the governing electrical code.

## 7.2 ELECTRICAL DATA

**Table 1 60 HZ MOTOR AMPS (approximate)**

Motor HP	RPM	208/3/60	230/3/60	460/3/60	380/3/50	575/3/60
1	890	4.6	4.2	2.1	2.1	1.7
1	1160	3.7	3.4	1.7	1.7	1.4
1.5	870	6.8	6.2	3.1	3.1	2.5
1.5	1160	5.5	5.2	2.6	2.6	-
2	870	9.5	8.6	4.3	4.3	3.4
2	1160	7.5	6.8	3.4	3.4	2.7
3	870	-	12.0	6.0	6.0	-
3	1160	10.6	9.6	4.8	4.8	3.8
3	1750	9.5	8.6	4.3	4.3	3.5
5	1160	15.9	14.4	7.2	7.2	5.8
5	1750	15.0	13.6	6.8	6.8	5.4
7.5	1160	25.0	22.0	11.0	11.0	8.8
7.5	1750	-	20.0	10.0	10.0	-

**Table 2 50 HZ MOTOR AMPS (approximate)**

Motor HP	KW	RPM	380/3/50
1.5	1.0	950	3.3
2	1.2	950	3.8
3	1.9	950	6.0
5	3.2	950	10.0
7.5	4.8	950	13.1
2	1.2	1450	3.0
3	1.9	1450	3.9
5	3.2	1450	7.0
7.5	4.8	1450	11.0
10	6.3	1450	13.5
15	9.5	1450	21.0

**Figure 4 Electric Defrost Wiring 230/3/60**

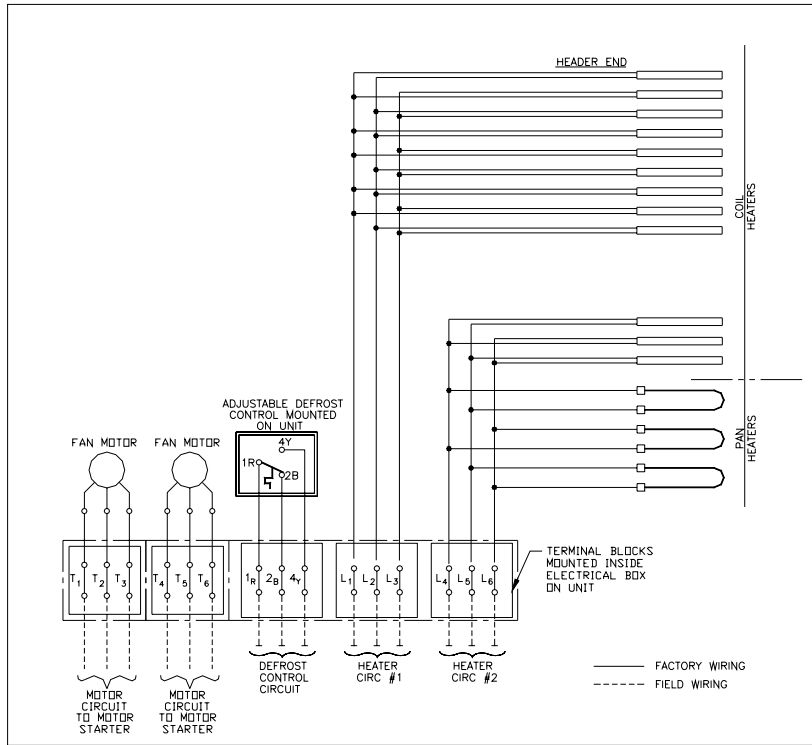

**Figure 5 Electric Defrost Wiring 460-575/3/60 or 380/3/50**

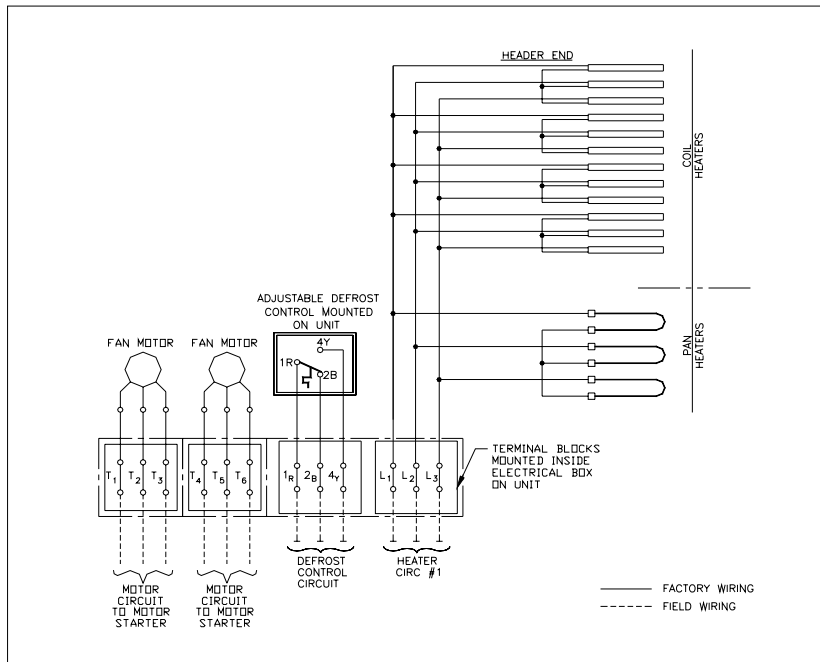

**Table 3 COIL (ED) HEATER AMPS**

Model	No. of Fans	230V, 460V, 575V / 3PH									380V / 3PH			Heater Access (in)
		Total Heaters KW	Amps								Total Heaters KW	Amps 380V		
			230V				460V		575V			Circ #1	Circ #2	
			Circ #1	Circ #2	Circ #3	Circ #4	Circ #1	Circ #2	Circ #1	Circ #2				
176	1	9.0	22.6	44.0	-	-	11.3	-	9.0	-	8.2	12.4	-	44
178	1	12.0	30.1	-	-	15.1	-	12.0	-	10.9	16.6	-		
216	1	10.8	27.1	64.0	-	-	13.6	-	10.8	-	9.8	14.9	-	64
218	1	14.4	36.1	-	-	18.1	-	14.5	-	13.1	19.9	-		
226	1	14.4	36.1	64.0	-	-	18.1	-	14.5	-	13.1	19.9	-	64
228	1	18.0	45.2	-	-	22.6	-	18.1	-	16.4	24.9	-		
246	1	14.4	36.1	64.0	-	-	18.1	-	14.5	-	13.1	19.9	-	64
248	1	18.0	45.2	-	-	22.6	-	18.1	-	16.4	24.9	-		
286	1	18.0	45.2	64.0	-	-	22.6	-	18.1	-	16.4	24.9	-	64
288	1	21.6	27.1	-	-	27.1	-	21.7	-	19.7	29.9	-		
316	1	25.2	36.1	64.0	-	-	31.6	-	25.3	-	22.9	34.8	-	64
318	1	28.8	36.1	-	-	36.1	-	28.9	-	26.2	39.8	-		
326	1	25.2	36.1	64.0	-	-	31.6	-	25.3	-	22.9	34.8	-	64
328	1	28.8	36.1	-	-	36.1	-	28.9	-	26.2	39.8	-		
336	2	18.0	45.2	52.0	-	-	22.6	-	18.1	-	16.4	24.9	-	52
338	2	24.0	30.1	-	-	30.1	-	24.1	-	21.8	33.2	-		
366	2	24.0	30.1	52.0	-	-	30.1	-	24.1	-	21.8	33.2	-	52
368	2	30.0	37.7	-	-	37.7	-	30.1	-	27.3	41.5	-		
406	2	24.0	30.1	52.0	-	-	30.1	-	24.1	-	21.8	33.2	-	52
408	2	30.0	37.7	-	-	37.7	-	30.1	-	27.3	41.5	-		
416	2	21.6	27.1	64.0	-	-	27.1	-	21.7	-	19.7	29.9	-	64
418	2	28.8	36.1	-	-	36.1	-	28.9	-	26.2	39.8	-		
446	2	28.8	36.1	64.0	-	-	36.1	-	28.9	-	26.2	39.8	-	64
448	2	36.0	45.2	-	-	45.2	-	36.1	-	32.8	24.9	24.9		
466	2	30.0	37.7	52.0	-	-	37.7	-	30.1	-	27.3	41.5	-	52
468	2	36.0	45.2	-	-	45.2	-	36.1	-	32.8	24.9	24.9		
486	2	28.8	36.1	64.0	-	-	36.1	-	28.9	-	26.2	19.9	19.9	64
488	2	36.0	45.2	-	-	45.2	-	36.1	-	32.8	24.9	24.9		
506	3	27.0	33.9	80.0	-	-	33.9	-	27.1	-	24.6	37.3	-	80
508	3	36.0	45.2	-	-	45.2	-	36.1	-	32.8	24.9	24.9		
516	2	42.0	37.7	52.0	37.7	-	26.4	26.4	42.2	-	38.2	29.0	29.0	52
518	2	48.0	37.7	-	37.7	-	30.1	30.1	24.1	24.1	43.7	33.2	33.2	
536	2	42.0	37.7	52.0	37.7	-	26.4	26.4	42.2	-	38.2	29.0	29.0	52
538	2	48.0	37.7	-	37.7	-	30.1	30.1	24.1	24.1	43.7	33.2	33.2	
556	3	36.0	33.9	80.0	33.9	-	45.2	-	36.1	-	32.8	24.9	24.9	80
558	3	45.0	33.9	-	33.9	-	28.2	28.2	45.2	-	40.9	31.1	31.1	
566	2	36.0	45.2	64.0	0.0	-	45.2	-	36.1	-	32.8	24.9	24.9	64
568	2	43.2	36.1	-	36.1	-	27.1	27.1	43.4	-	39.3	29.9	29.9	
606	3	36.0	45.2	80.0	0.0	-	45.2	0.0	36.1	-	32.8	24.9	24.9	80
608	3	45.0	33.9	-	33.9	-	28.2	28.2	45.2	-	40.9	31.1	31.1	
616	2	50.4	45.2	64.0	45.2	-	31.6	31.6	25.3	25.3	45.9	34.8	34.8	64
618	2	57.6	36.1	-	36.1	36.1	36.1	36.1	28.9	28.9	52.4	39.8	39.8	
646	2	50.4	45.2	64.0	45.2	-	31.6	31.6	25.3	25.3	45.9	34.8	34.8	64
648	2	57.6	36.1	-	36.1	36.1	36.1	36.1	28.9	28.9	52.4	39.8	39.8	
706	3	45.0	33.9	80.0	33.9	-	28.2	28.2	45.2	-	40.9	31.1	31.1	80
708	3	54.0	45.2	-	45.2	-	33.9	33.9	27.1	27.1	49.1	37.3	37.3	

\* Heater removal is required at the refrigerant connection end of the unit

\*\* Heater removal is required at both ends of the unit

**Table 4 COIL AND DRAIN PAN (EDL) HEATER AMPS**

Model	No. of Fans	230V, 460V, 575V / 3PH								380V / 3PH			Heater Access (in)		
		Total Heaters KW	Amps								Total Heaters KW	380V			
			230V				460V		575V			Circ #1		Circ #2	Circ #3
			Circ #1	Circ #2	Circ #3	Circ #4	Circ #1	Circ #2	Circ #1	Circ #2					
176	1	13.4	33.7	-	44.0	-	16.9	-	13.5	-	12.2	18.6	-	-	44.0
178	1	16.4	41.2	-	-	-	20.6	-	16.5	-	14.9	22.7	-	-	
216	1	16.1	40.5	-	64.0	-	20.2	-	16.2	-	14.7	22.3	-	-	64.0
218	1	19.7	22.4	27.1	-	-	24.8	-	19.8	-	17.9	27.3	-	-	
226	1	19.7	22.4	27.1	64.0	-	24.8	-	19.8	-	17.9	27.3	-	-	64.0
228	1	23.3	31.4	27.1	-	-	29.3	-	23.4	-	21.2	32.2	-	-	
246	1	19.7	22.4	27.1	64.0	-	24.8	-	19.8	-	17.9	27.3	-	-	64.0
248	1	26.9	31.4	36.1	-	-	33.8	-	27.0	-	24.5	37.2	-	-	
286	1	23.3	31.4	27.1	64.0	-	29.3	-	23.4	-	21.2	32.2	-	-	64.0
288	1	30.5	40.5	36.1	-	-	38.3	-	30.6	-	27.8	42.2	-	-	
316	1	30.5	40.5	36.1	64.0	-	38.3	-	30.6	-	27.8	42.2	-	-	64.0
318	1	37.7	31.4	27.1	-	-	47.3	-	37.9	-	34.3	27.3	24.9	-	
326	1	30.5	40.5	36.1	64.0	-	38.3	-	30.6	-	27.8	42.2	-	-	64.0
328	1	37.7	31.4	27.1	-	-	47.3	-	37.9	-	34.3	27.3	24.9	-	
336	2	26.5	33.2	33.2	52.0	-	33.2	-	26.6	-	24.1	36.6	-	-	52.0
338	2	32.5	40.7	40.7	-	-	40.7	-	32.6	-	29.5	44.9	-	-	
366	2	32.5	40.7	40.7	52.0	-	40.7	-	32.6	-	29.5	44.9	-	-	52.0
368	2	38.5	33.2	33.2	-	-	24.1	24.1	38.6	-	35.0	26.6	26.6	-	
406	2	32.5	40.7	40.7	52.0	-	40.7	-	32.6	-	29.5	44.9	-	-	52.0
408	2	44.5	37.7	36.3	-	-	27.9	27.9	44.6	-	40.5	30.7	30.7	-	
416	2	31.8	39.9	39.9	64.0	-	39.9	-	31.9	-	28.9	43.9	-	-	64.0
418	2	39.0	48.9	48.9	-	-	24.5	24.5	39.1	-	35.5	27.0	27.0	-	
446	2	39.0	30.9	36.1	64.0	-	24.5	24.5	39.1	-	35.5	27.0	27.0	-	64.0
448	2	46.2	39.9	39.9	-	-	29.0	29.0	46.4	-	42.0	31.9	31.9	-	
466	2	38.5	33.2	33.2	52.0	-	24.1	24.1	38.6	-	35.0	26.6	26.6	-	52.0
468	2	50.5	40.7	45.2	-	-	31.7	31.7	25.3	25.3	45.9	34.9	34.9	-	
486	2	39.0	30.9	36.1	64.0	-	24.5	24.5	39.1	-	35.5	27.0	27.0	-	64.0
488	2	53.4	45.2	43.6	-	-	33.5	33.5	26.8	26.8	48.6	36.9	36.9	-	
506	3	39.5	33.9	31.4	80.0	-	24.8	24.8	39.7	-	36.0	27.3	27.3	-	80.0
508	3	48.5	38.3	45.2	-	-	30.4	30.4	24.4	24.4	44.1	33.5	33.5	-	
516	2	50.5	40.7	45.2	52.0	-	31.7	31.7	25.3	25.3	45.9	34.9	34.9	-	52.0
518	2	62.5	40.7	37.7	-	37.7	39.2	39.2	31.4	31.4	56.8	43.2	43.2	-	
536	2	50.5	40.7	45.2	52.0	-	31.7	31.7	25.3	25.3	45.9	34.9	34.9	-	52.0
538	2	62.5	40.7	37.7	-	37.7	39.2	39.2	31.4	31.4	56.8	43.2	43.2	-	
556	3	48.5	38.3	45.2	80.0	-	30.4	30.4	24.4	24.4	44.1	33.5	33.5	-	80.0
558	3	57.5	38.3	33.9	-	33.9	36.1	36.1	28.9	28.9	52.3	39.8	39.8	-	
566	2	46.2	39.9	39.9	64.0	-	29.0	29.0	23.2	23.2	42.0	31.9	31.9	-	64.0
568	2	60.6	39.9	36.1	-	36.1	38.0	38.0	30.4	30.4	55.1	41.9	41.9	-	
606	3	48.5	38.3	45.2	80.0	-	30.4	30.4	24.4	24.4	44.1	33.5	33.5	-	80.0
608	3	66.5	38.3	45.2	-	45.2	41.7	41.7	33.4	33.4	60.5	46.0	46.0	-	
616	2	60.6	39.9	36.1	64.0	36.1	38.0	38.0	30.4	30.4	55.1	41.9	41.9	-	64.0
618	2	-	-	-	-	-	47.1	47.1	37.6	37.6	68.2	34.8	34.0	34.8	
646	2	60.6	39.9	36.1	64.0	36.1	38.0	38.0	30.4	30.4	55.1	41.9	41.9	-	64.0
648	2	-	-	-	-	-	47.1	47.1	37.6	37.6	68.2	34.8	34.0	34.8	
706	3	57.5	38.3	33.9	80.0	33.9	36.1	36.1	28.9	28.9	52.3	39.8	39.8	-	80.0
708	3	-	-	-	-	-	47.4	47.4	37.9	37.9	68.7	33.5	37.3	33.5	

\* Heater removal is required at the refrigerant connection end of the unit

\*\* Heater removal is required at both ends of the unit

### **7.3 SUGGESTED NO DEFROST REQUIREMENT SEQUENCE OF OPERATION**

Used for units with a suction temperature above freezing.

- A. When the room thermostat calls for cooling, refrigerant begins flowing to the unit.
- B. The fan motor(s) is(are) energized.
- C. When the thermostat is satisfied, refrigerant stops flowing to the unit.
- D. The fan motor(s) are de-energized.

### **7.4 SUGGESTED AIR DEFROST SEQUENCE OF OPERATION**

Used for units with a suction temperature below freezing, but a room temperature above +36°F.

- A. A defrost timer is wired into the fan motor(s) control.
- B. The timer turns off the liquid line solenoid valve at a predetermined time, but the fan motor(s) continue to operate.
- C. When the refrigerant is completely boiled out of the unit, the fan motor(s) still continue to operate so that the room air temperature melts the coil frost.
- D. At a second predetermined time, the timer energizes the liquid solenoid valve and refrigeration resumes.

The timer settings are to be programmed per the need of each evaporator.

### **7.5 SUGGESTED ELECTRIC DEFROST SEQUENCE OF OPERATION**

Used for units with a suction temperature below freezing. The Electric Defrost cycle is time clock initiated and temperature terminated. Three or four defrost cycles per 24 hour period are typical. The following sequence is based on the Paragon 8145 or equal time clock.

- A. Power is supplied to the defrost timer.
- B. The defrost termination thermostat is off and the defrost heaters are off.
- C. The unit operates in cooling mode.
- D. Upon initiation of the defrost cycle the time clock turns off the liquid line solenoid valve.
- E. After a site determined time period the timer de-energizes the fan motor(s) and energizes the defrost heaters.
- F. The heaters, positioned within the coil turbo spacers in the fin pack, heat up the fins directly to melt the accumulated frost.
- G. When the coil reaches the temperature setting of the defrost termination thermostat the thermostat opens the defrost circuit to cut off power to the heaters.
- H. The defrost timer energizes the liquid line solenoid valve allowing refrigerant to flow into the unit, cooling the coil and refreezing any remaining condensate drops that are still present.
- I. The fan motor(s) is(are) started through the fan delay thermostat temperature setting, putting the unit in the cooling cycle.

The timer settings and the adjustable defrost termination fan delay thermostat settings are to be programmed per the need of each evaporator.

### **7.6 SUGGESTED HOT GAS DEFROST SEQUENCE OF OPERATION**

Used for units with a suction temperature below freezing. The Hot Gas Defrost cycle is time clock initiated and terminated. The following sequence is based on the Hansen Frost Master or equal time clock.

- A. Power is supplied to the defrost timer.
- B. The unit operates in the cooling cycle.
- C. Upon initiation of the defrost cycle, the defrost time clock turns off the liquid line solenoid valve. The fan motor(s) continues to operate to boil off the remaining refrigerant in the coil tubes.

- D. After a predetermined time period the defrost timer de-energizes the fan motor(s) and energizes the hot gas supply solenoid valve. Note that larger units may also have a “soft defrost” solenoid to slowly pressurize the coil, which will open before the main hot gas supply solenoid.
- E. Hot gas flows into the unit and warms up the tubes and fins (and drain pan if a hot gas pan was supplied), melting the accumulated frost.
- F. Approximately eight to twelve minutes after starting the hot gas defrost cycle the defrost time clock should de-energize the hot gas supply solenoid valve. If the unit is in defrost for a much longer period of time the condensate on the tubes and fins could “steam” and refreeze on the fan cabinet, fan(s), or venturi causing maintenance problems.
- G. The defrost time clock should energize the vent solenoid, allowing any remaining high pressure gas to escape the coil.
- H. The defrost timer energizes the liquid line and suction line solenoid valves allowing refrigerant to flow into the unit, cooling the coil and refreezing any remaining condensate drops that are still present.
- I. The fan motor(s) is(are) energized after a preset fan delay in the time clock and the unit is in the cooling cycle.

The timer settings are to be programmed per the need of each evaporator.

## **7.7 SUGGESTED WATER DEFROST SEQUENCE OF OPERATION**

Used for units with a suction temperature below freezing. The Water Defrost cycle is time clock initiated and terminated.

- A. Power is supplied to the defrost timer.
- B. The unit operates in the cooling cycle.
- C. Upon initiation of the defrost cycle, the defrost time clock turns off the liquid line solenoid valve. The fan motor(s) continues to operate to boil off the remaining refrigerant in the coil tubes.
- D. After a predetermined time period the defrost timer de-energizes the fan motor(s) and energizes the water supply solenoid valve.
- E. Water flows onto the unit and warms up the tubes, fins, and drain pan, melting the accumulated frost.
- F. Approximately ten minutes after starting the water defrost cycle the defrost time clock should de-energize the water supply solenoid valve.
- G. The defrost time clock should allow the remaining water to drip off of the coil surface.
- H. The defrost timer energizes the liquid line solenoid valve allowing refrigerant to flow into the unit, cooling the coil and refreezing any remaining condensate drops that are still present.
- I. The fan motor(s) is(are) energized after a preset fan delay in the time clock and the unit is in the cooling cycle.

The timer settings are to be programmed per the need of each evaporator.

## **8 OPERATION**

### **8.1 PRE-START UP**

After the installation is completed, a review of the following items should be performed before the system is placed into operation:

- A. Check electrical connections, fan bushing set screws, motor mount bolts, coil flange bolts, drain pan flange bolts, and all other fasteners for tightness. If required, be sure the thermostatic expansion valve bulb is properly located, strapped, and insulated.
- B. For systems with a defrost time clock check the timer to see that it is set for the correct time of day and the starting pins have been installed (normally two or three sets per day). Defrost should be scheduled when the freezer doors are not likely to be open.
- C. When the unit is first started the room temperature is typically above the contact closing temperature of the fan delay thermostat, if a fan delay thermostat is provided for Electric Defrost

units (see that particular units electrical diagram). The fans may remain off for a lengthy period of time. To prevent this delay it is permissible to install a temporary jumper wire between terminals "1R" and "2B". Once the room temperature is below +25°F the jumper wire should be removed.

- D. For PH style units make sure that the grease lines to the bearings are filled with grease. See Maintenance section 9.5 or 9.6 for recommended grease types. The motors for either PC or PH units are greased from the motor manufacturer.

## **8.2 OPERATION CHECKOUT**

With the system operating, check the supply voltage. The voltage must be within +/- 10% of the voltage marked on the unit nameplate and the phase to phase unbalance should be 2% or less.

LISTEN CAREFULLY to the unit to make sure there are no unusual sounds. Sounds such as a noisy motor, the fan(s) scraping on the housing, or loose fasteners allowing parts to rattle need to be addressed immediately before continued unit operation.

Check the room THERMOSTAT setting. Be sure it functions properly.

For RECIRCULATED refrigeration systems the hand expansion valve should be opened slowly until either condensate or frost forms on the return bends from the bottom to the top of the coil. A good indicator is when the defrost relief valve reads 5 psi above suction pressure.

For FLOODED refrigeration systems check to make sure the float valve is working properly and allows refrigerant into the drum to the appropriate level when the level is sufficiently low. If a hand expansion valve has been added, the valve should be set to allow liquid make up 70% of the time.

For DIRECT EXPANSION systems let the system balance out at the desired room temperature and check the operation of the expansion valve by properly measuring the superheat at the sensing bulb. As much as thirty minutes may be required for the new balance to take place after an adjustment is made.

For BRINE or WATER COOLING systems keep the closest vent to the coil open while the fluid fills the coil to allow trapped air to escape. Close the vent valve once fluid flows out of the valve and check for water hammer in the coil.

With HOT GAS DEFROST systems allow the coil to frost, then manually advance the defrost timer to initiate a defrost cycle. Observe the defrost cycle to see if all controls are functioning properly and that the coil is clear of all frost before the system returns to refrigeration. Adjust the time clock pins if necessary. Reset the defrost timer to the correct time of day. A defrost cycle is only needed when the frost build up is such that it impedes the airflow through the coil. The defrost requirements will vary on each installation and may change depending on the time of the year and other conditions.

With ELECTRIC DEFROST systems allow the coil to frost then manually advance the defrost timer to initiate a defrost cycle. Observe the defrost cycle to see if all controls are functioning properly and that the coil is clear of all frost before the system returns to refrigeration. Adjust the time clock pins if necessary. Reset the defrost timer to the correct time of day. A defrost cycle is only needed when the frost build up is such that it impedes the airflow through the coil. The defrost requirements will vary on each installation and may change depending on the time of the year and other conditions.

With WATER DEFROST systems allow the coil to frost then manually advance the defrost timer to initiate a defrost cycle. Observe the defrost cycle to see if all controls are functioning properly and that the coil is clear of all frost before the system returns to refrigeration. Adjust the time clock pins if necessary. Reset the defrost timer to the correct time of day. A defrost cycle is only needed when the frost build up is such that it impedes the airflow through the coil. The defrost requirements will vary on each installation and may change depending on the time of the year and other conditions.

## 9 MAINTENANCE

A preventive maintenance schedule should be established as soon as the PC Series III unit is installed. The unit should be inspected periodically for proper operation and build up of frost and debris.

**WARNING: All power to the evaporator must be off before cleaning or performing maintenance.**

### 9.1 DRAIN PAN

Inspect and clean the drain pan to insure free drainage of condensate. The drain pan should be cleaned regularly with warm water and soap.

If the drain pan needs to be removed, support the long dimension of the pan from underneath with a minimum of two 4x4s for one and two fan units, or two 6x6s for three and four fan units, so the outer sheetmetal skin does not buckle and become damaged. **Do not point load the center of the support beam.** For longer pans more than one lifting device may be needed to keep the pan balanced when lifting. If the drain pan uses hot gas defrost make sure the coil is completely pumped out and isolated with hand valves to prevent refrigerant from escaping to the atmosphere. Remove the hot gas piping or electric wires if the unit has an electric defrost drain pan. Remove the drain line so that it is out of the way of the pan when it is being lowered. Remove the drain pan attachment bolts from the bottom of the evaporator unit and slowly lower the pan from the unit. Assemble pan in reverse order. Replace hot gas interlocking gaskets before tightening flange bolts.

### 9.2 COIL AND CABINET

Clean the coil, fan cabinet, fan(s), and fan guard(s) with warm water and soap. A low pressure water hose is recommended to avoid water entering into electrical components and causing equipment failure.

The evaporator coil should be checked once a month for proper defrosting. Many variables affect coil frosting such as room temperature, type of product being stored or processed, how often new product is brought in, and the length of time the door to the room remains open. Summer conditions of high humidity can cause heavier frost loads and it may be necessary to change the number of defrost cycles seasonally.

### 9.3 FAN GUARD OR LONG THROW ADAPTER REPLACEMENT

To remove a fan guard or long throw adapter for fan-motor maintenance, or for guard or adapter replacement, make sure all electrical power to the unit has been turned off before any work is performed. Remove the two nuts on the lowest part of the guard or adapter first. While holding the guard or adapter to the unit with one hand use your other hand to remove the top two nuts. Use both hands to remove the guard or adapter. Reassemble in the reverse order.

### 9.4 FAN REPLACEMENT

If a fan is out of balance, damaged, or needs to be replaced, the unit does not need to be at floor level for maintenance. Make sure all electrical power to the unit has been turned off before any work is performed. Remove the fan guard as described in Section 9.3. Remove the two or three bolts from the bushing that hold the fan onto the motor shaft. Insert the bolts that were just removed into the auxiliary holes in the fan bushing. Insert a small, thin piece of metal, like a dime or similar thickness, between the end of the bolt and the fan hub. By tightening the bolts against the hard metal and the hub the bushing will be pulled from the motor shaft. Remove the bushing, fan, and key. Clean and deburr the motor shaft, key, and keyway if necessary.

Place the new fan onto the motor shaft so that the fan blades cup the air away from the coil, all the way to the motor body. Typically the center hub of the fan has an extension that should point towards the motor. Align the keyway on the taper-lock bushing and the motor shaft. Insert the key and tap the key



and the bushing onto the motor shaft until they are flush with the end of the motor shaft. Rotate the fan until the non-threaded holes in the bushing align with the threaded holes in the fan hub. Insert new bolts through the holes in the bushing. Evenly tighten the bolts, drawing the fan over the bushing. The bushing should be flush with the motor shaft when finished. Tighten the bolts to 14 ft-lbs. When the bolts are tight, tap the key with a punch to make sure the key is tight. Reattach the fan guard or adapter.

**IMPORTANT: If the key slips, remove the fan and start over, possibly with a new key and bushing. If the key is not tight the fan may come off on startup, or during operation causing damage.**

## **9.5 PC TYPE UNIT MOTOR REPLACEMENT**

When greasing the motor use Chevron RPM Arctic, Esso Beacon #325, or equivalent grease. Use a low pressure grease gun to avoid over lubrication or destruction of the bearing seals.

Make sure all electrical power to the unit has been turned off before any work is performed. To replace a motor a lifting device may be required for the heavy motors. Remove the fan guard and fan as described in Sections 9.3 and 9.4. Remove the motor junction box cover and disconnect the motor leads.

If the motor being removed is the same frame size as the replacement motor, use a pencil to trace an outline on the unit motor mount for the replacement motor installation. For safety, the motor should be supported before the hold down bolts and nuts are taken apart. Remove the motor hold-down bolts and remove the motor from the housing.

Remove the motor junction box cover. Set the replacement motor in place using the pencil marks as a guide. Connect the wires to the motor following the wiring schematic for the motor. Make certain the motor is wired for the correct supply voltage. Attach the motor junction box cover. Measure from the shaft center to the outside of the fan orifice at several angles. The motor shaft should be centered. If the motor is too low, shim the base up with washers or use a motor base conversion kit if the frame sizes are different. If the motor is too high, the motor mount will need to be lowered in the fan cabinet. When the motor shaft is centered, insert the bolts and nuts to hold the motor in place. Only slightly tighten the bolts at this time in case the motor needs to be adjusted after the fan is installed.

Place the new fan, with the numbers cast on the fan hub toward the installer, onto the motor shaft all the way to the motor body. Align the keyway on the taper-lock bushing and the motor shaft. Insert the key and tap the key and the bushing onto the motor shaft until they are flush with the end of the motor shaft. Rotate the fan until the non-threaded holes in the bushing align with the threaded holes in the fan hub. Insert new bolts through the holes in the bushing. Evenly tighten the bolts, drawing the fan over the bushing. Tighten the bolts to 14 ft-lbs. When the bolts are tight, tap the key with a punch to make sure the key is tight. Reattach the fan guard or adapter.

**IMPORTANT: If the key slips, remove the fan and start over, possibly with a new key and bushing. If the key is not tight the fan may come off on startup, or during operation causing damage.**

The fan-motor assembly should already be aligned to have equal clearance between the tip of the fan blades and the sheetmetal orifice. Position the fan-motor assembly so that the blades are recessed one inch from the front edge of the orifice, which is roughly in the center of the orifice. Complete tightening the fan-motor assembly bolts and nuts to the mounting base. Replace the fan guard or adapter as described in Section 9.3.

When starting the motor make sure the fan is rotating in the proper counter clockwise direction. If the fan rotates clockwise, stop the motor, shut off all power to the unit, and change the motor wiring for counter clockwise rotation.

## **9.6 45° DOWN DISCHARGE or PH TYPE UNIT MOTOR REPLACEMENT**

When greasing the motor use Chevron RPM Arctic, Esso Beacon #325, or equivalent grease. Use a low pressure grease gun to avoid over lubrication or destruction of the bearing seals.

Replacing a motor for a 45° Down Discharge or PH type of unit is basically the same as in Section 9.5, with the following extra precautions:

- Extra care should be taken to avoid the motor and/or fan from falling down through the air discharge, causing harm or damage.
- The motor should be supported through the access plate directly above the motor in the fan cabinet.
- The heavy fan should be supported before and during the taper-lock bushing removal or installation.
- The motor base bolts and nuts should be fully tightened whenever they are installed.
- The grease line to each motor needs to be removed when removing the motor and reattached when the motor is installed.
- For a PH type of unit, the large front 90° down piece of sheetmetal can be removed for access to the motor and fan. The panel has a handle mounted for ease of removal.

## **9.7 ELECTRIC DEFROST HEATERS**

Inspect the electric defrost heater ends to determine if they are operating. A heater will be operating properly when the heater is observed to be glowing during the defrost cycle. If a heater rod is cold during the defrost cycle it will need to be replaced.

Coil heaters require horizontal removal from one end of the unit. On two or three fan units heater rods are on both ends of the unit. Remove heater wire from terminal block and note where original wires were located. Rotate the heater rod so that the heater and retainer clip can be slid through the coil endplate slot. Remove clip from the old heater rod and install on the new heater rod in approximately the same location as the original heater. Install new heater rod in the coil original coil slot, rotate the rod 90°, and replace the wires in the positions of the original wires in the terminal block.

Drain pan heaters require the drain pan to be removed. Support the long dimension of the pan from underneath with a minimum of two 4x4s for one and two fan units or two 6x6s for three and four fan units so the outer sheetmetal skin does not buckle and become damaged. For longer pans more than one lifting device may be needed to keep the pan balanced when lifting. Remove the heater wires from the terminal block(s). Remove the drain line so that it is out of the way of the pan when it is being lowered. Remove the drain pan attachment bolts from the bottom of the evaporator unit and slowly lower the pan from the unit. Remove the nuts from the heater hold down brackets and remove the brackets. Replace the heater. Replace the hold down brackets and assemble the pan in reverse order. Rewire the heaters in the original terminal block(s).

## **9.8 WATER DEFROST DISTRIBUTION PAN**

The Water Defrost distribution pan is removable from the rear of the unit for cleaning or replacement. Disconnect the water piping from the pan inlet connection. Remove the access plate from the front of the water pan section and slide out the water distribution pan. Reassemble in the reverse order.

## 10 REPLACEMENT PARTS LIST

Following are the major replacement parts of the standard PC Series III units. Call sales representative or factory to identify non-standard replacement parts. The full Model Number, Serial Number, and voltage will be necessary to identify the correct replacement part.

**Table 5 STANDARD MOTOR, FAN, BUSHING (30" DIA. FAN UNITS)  
(MODELS 17, 21, 33, 41, 50, 58, 68)**

<b>PART</b>	<b>1 HP 1160 RPM</b>	<b>1.5 HP 1160 RPM</b>	<b>2 HP 1160 RPM</b>	<b>3 HP 1750 RPM</b>
Fan	E315867	E315868	E315869	E315870
Bushing	E315866	BHHA12	E315858	BHHA12
230/460V ODP Motor	11081	11084	11086	11089
230/460 V TEFC Motor	E205173	11515	11516	11519
575 V TEFC Motor	E313857	E313214	E311465	E315514

**Table 6 STANDARD MOTOR, FAN, BUSHING (36" DIA. FAN UNITS)  
(MODELS 22, 24, 36, 40, 44, 48, 55, 60, 65, 72, 75, 82)**

<b>PART</b>	<b>1 HP 850 RPM</b>	<b>1.5 HP 850 RPM</b>	<b>2 HP 1160 RPM</b>	<b>3 HP 1160 RPM</b>	<b>5 HP 1160 RPM</b>	<b>5 HP 1750 RPM</b>
Fan	E315759	E315860	E315759	E315849	E315851	E315847
Bushing	BHHA12	E315858	BHHA12	E315846	E315846	BHHA12
230/460V ODP Motor	11514	11532	11086	11088	11090	11091
230/460 V TEFC Motor	E311214	E311880	11516	11518	11526	11520
575 V TEFC Motor	E315703	E313568	E311465	E313289	E312330	E311765

**Table 7 STANDARD MOTOR, FAN, BUSHING (42" DIA. FAN UNITS)  
(MODELS 28, 31, 32, 46, 51, 53, 56, 61, 64, 70, 74, 79, 84, 90, 95, 96, 103, 110)**

<b>PART</b>	<b>1.5 HP 850 RPM</b>	<b>2 HP 850 RPM</b>	<b>3 HP 1160 RPM</b>	<b>5 HP 1160 RPM</b>	<b>7.5 HP 1160 RPM</b>
Fan	E315855	E315852	E315855	E315852	E315853
Bushing	BHP112	11679	11679	11679	BHP11A
230/460V ODP Motor	11532	E310145	11088	11090	E310251
230/460 V TEFC Motor	E311880	E311775	11518	11526	E310984
575 V TEFC Motor	E313568	E313922	E313289	E313568	E313633

**Table 8 FAN GUARDS & LONG THROW ADAPTERS**

<b>FAN SIZE</b>	<b>FAN GUARD P/N</b>	<b>LONG THROW ADAPTER P/N</b>
30" Dia. Fan	E280792	CE310525
36" Dia. Fan	E314249	CE310440
42" Dia. Fan	E314250	CE310441

**Table 9 230 & 460 VOLT ELECTRIC DEFROST HEATERS**

UNIT SIZE	COIL HEATER QTY EDL UNIT	COIL HEATER QTY EDL UNIT	230/3/60 COIL HEATER P/N	460/3/60 COIL HEATER P/N	DRAIN PAN HEATER QTY	230/3/60 PAN HEATER P/N	460/3/60 PAN HEATER P/N
17 6 ROW	9	12	17784	17781	3	21757	21763
17 8 ROW	12	15	17784	17781	3	21757	21763
21 6 ROW	9	12	E311562	E311099	3	E312205	E312206
21 8 ROW	12	15	E311562	E311099	3	E312205	E312206
22 6 ROW	12	15	E311562	E311099	3	E312205	E312206
22 8 ROW	15	18	E311562	E311099	3	E312205	E312206
24 6 ROW	12	15	E311562	E311099	3	E312205	E312206
24 8 ROW	15	21	E311562	E311099	3	E312205	E312206
28 6 ROW	15	18	E311562	E311099	3	E312205	E312206
28 8 ROW	18	24	E311562	E311099	3	E312205	E312206
31 6 ROW	21	24	E311562	E311099	3	E312205	E312206
31 8 ROW	24	30	E311562	E311099	3	E312205	E312206
32 6 ROW	21	24	E311562	E311099	3	E312205	E312206
32 8 ROW	24	30	E311562	E311099	3	E312205	E312206
33 6 ROW	18	24	17784	17781	6	21759	21765
33 8 ROW	24	30	17784	17781	6	21759	21765
36 6 ROW	24	30	17784	17781	6	21759	21765
36 8 ROW	30	36	17784	17781	6	21759	21765
40 6 ROW	24	30	17784	17781	6	21759	21765
40 8 ROW	30	42	17784	17781	6	21759	21765
41 6 ROW	18	24	E311562	E311099	6	21760	21766
41 8 ROW	24	30	E311562	E311099	6	21760	21766
44 6 ROW	24	30	E311562	E311099	6	21760	21766
44 8 ROW	30	36	E311562	E311099	6	21760	21766
46 6 ROW	30	36	17784	17781	6	21759	21765
46 8 ROW	36	48	17784	17781	6	21759	21765
48 6 ROW	24	30	E311562	E311099	6	21760	21766
48 8 ROW	30	42	E311562	E311099	6	21760	21766
50 6 ROW	18	24	17785	17782	6	21761	21767
50 8 ROW	24	30	17785	17782	6	21761	21767
51 6 ROW	42	48	17784	17781	6	21759	21765
51 8 ROW	48	60	17784	17781	6	21759	21765
53 6 ROW	42	48	17784	17781	6	21759	21765
53 8 ROW	48	60	17784	17781	6	21759	21765
55 6 ROW	24	30	17785	17782	6	21761	21767
55 8 ROW	30	36	17785	17782	6	21761	21767
56 6 ROW	30	36	E311562	E311099	6	21760	21766
56 8 ROW	36	48	E311562	E311099	6	21760	21766
60 6 ROW	24	30	17785	17782	6	21761	21767
60 8 ROW	30	42	17785	17782	6	21761	21767
61 6 ROW	42	48	E311562	E311099	6	21760	21766
61 8 ROW	48	60	E311562	E311099	6	21760	21766
64 6 ROW	42	48	E311562	E311099	6	21760	21766
64 8 ROW	48	60	E311562	E311099	6	21760	21766
70 6 ROW	30	36	17785	17782	6	21761	21767
70 8 ROW	36	48	17785	17782	6	21761	21767

Consult factory for heaters with voltages other than 230 or 460 volt.

**DEFROST TERMINATION THERMOSTAT: P/N E205004**

**Table 10 575 & 380 VOLT ELECTRIC DEFROST HEATERS**

UNIT SIZE	COIL HEATER QTY ED UNIT	COIL HEATER QTY EDL UNIT	575/3/60 COIL HEATER P/N	380/3/50 COIL HEATER P/N	DRAIN PAN HEATER QTY	575/3/60 PAN HEATER P/N	380/3/50 PAN HEATER P/N
17 6 ROW	9	12	E315470	11784	3	E315474	21757
17 8 ROW	12	15	E315470	11784	3	E315474	21757
21 6 ROW	9	12	E315484	E311562	3	E315485	E312205
21 8 ROW	12	15	E315484	E311562	3	E315485	E312205
22 6 ROW	12	15	E315484	E311562	3	E315485	E312205
22 8 ROW	15	18	E315484	E311562	3	E315485	E312205
24 6 ROW	12	15	E315484	E311562	3	E315485	E312205
24 8 ROW	15	21	E315484	E311562	3	E315485	E312205
28 6 ROW	15	18	E315484	E311562	3	E315485	E312205
28 8 ROW	18	24	E315484	E311562	3	E315485	E312205
31 6 ROW	21	24	E315484	E311562	3	E315485	E312205
31 8 ROW	24	30	E315484	E311562	3	E315485	E312205
32 6 ROW	21	24	E315484	E311562	3	E315485	E312205
32 8 ROW	24	30	E315484	E311562	3	E315485	E312205
33 6 ROW	18	24	E315470	11784	6	E315476	21759
33 8 ROW	24	30	E315470	11784	6	E315476	21759
36 6 ROW	24	30	E315470	11784	6	E315476	21759
36 8 ROW	30	36	E315470	11784	6	E315476	21759
40 6 ROW	24	30	E315470	11784	6	E315476	21759
40 8 ROW	30	42	E315470	11784	6	E315476	21759
41 6 ROW	18	24	E315484	E311562	6	E315477	21760
41 8 ROW	24	30	E315484	E311562	6	E315477	21760
44 6 ROW	24	30	E315484	E311562	6	E315477	21760
44 8 ROW	30	36	E315484	E311562	6	E315477	21760
46 6 ROW	30	36	E315470	11784	6	E315476	21759
46 8 ROW	36	48	E315470	11784	6	E315476	21759
48 6 ROW	24	30	E315484	E311562	6	E315477	21760
48 8 ROW	30	42	E315484	E311562	6	E315477	21760
50 6 ROW	18	24	E315471	17785	6	E315478	21761
50 8 ROW	24	30	E315471	17785	6	E315478	21761
51 6 ROW	42	48	E315470	11784	6	E315476	21759
51 8 ROW	48	60	E315470	11784	6	E315476	21759
53 6 ROW	42	48	E315470	11784	6	E315476	21759
53 8 ROW	48	60	E315470	11784	6	E315476	21759
55 6 ROW	24	30	E315471	17785	6	E315478	21761
55 8 ROW	30	36	E315471	17785	6	E315478	21761
56 6 ROW	30	36	E315484	E311562	6	E315477	21760
56 8 ROW	36	48	E315484	E311562	6	E315477	21760
60 6 ROW	24	30	E315471	17785	6	E315478	21761
60 8 ROW	30	42	E315471	17785	6	E315478	21761
61 6 ROW	42	48	E315484	E311562	6	E315477	21760
61 8 ROW	48	60	E315484	E311562	6	E315477	21760
64 6 ROW	42	48	E315484	E311562	6	E315477	21760
64 8 ROW	48	60	E315484	E311562	6	E315477	21760
70 6 ROW	30	36	E315471	17785	6	E315478	21761
70 8 ROW	36	48	E315471	17785	6	E315478	21761

Consult factory for heaters with voltages other than 230 or 460 volt.

**DEFROST TERMINATION THERMOSTAT: P/N E205004**

**Table 11 REPLACEMENT DRAIN PANS**

<b>DRAIN PAN TYPE (MODEL #)</b>	<b>1 FAN SHORT SECTION (17)</b>	<b>1 FAN LONG SECTION (21, 22, 24, 28, 31, 32)</b>	<b>2 FAN SHORT SECTION (33, 36, 40, 46, 51, 53)</b>	<b>2 FAN LONG SECTION (41, 44, 48, 56, 61, 64)</b>
Drain Pan Dimensions	23.5" x 81"	23.5" x 93"	23.5" x 137"	23.5" x 161"
Aluminum (Air, HGC, ED) Non-Insulated	CE320590	CE320207	CE320592	CE320208
Aluminum (Air, HGC, ED) Insulated-Galv. Cover	CE320584	CE320203	CE320585	CE320204
Aluminum (Air, HGC, ED) Insulated-Stainless Cover	CE321152	CE321156	CE321159	CE321162
Aluminum (230V - EDL) Insulated – Galv. Cover	CE320720	CE320781	CE320722	CE320783
Aluminum (460V - EDL) Insulated – Galv. Cover	CE320721	CE320782	CE320723	CE320784
Aluminum (575V - EDL) Insulated – Galv. Cover	CE321382	CE321386	CE321390	CE321394
Aluminum (380V - EDL) Insulated – Galv. Cover	CE321383	CE321387	CE321391	CE321395
Aluminum (230V - EDL) Insulated – Stainless Cover	CE303802	CE303818	CE303834	CE303850
Aluminum (460V - EDL) Insulated – Stainless Cover	CE303803	CE303819	CE303835	CE303851
Aluminum (575V - EDL) Insulated – Stainless Cover	CE321384	CE321388	CE321392	CE321396
Aluminum (380V - EDL) Insulated – Stainless Cover	CE321385	CE321389	CE321393	CE321397
Aluminum (WD) Non-Insulated	CE321175	CE320591	CE320593	CE320554
Stainless Steel (WD) Non-Insulated	CE231402	CE231403	CE231404	CE231405
Stainless Waffle (HGP/HGS) Insulated-Galv. Cover	CE320581	CE320009	CE320582	CE320010
Stainless Waffle (HGP/HGS) Insulated-Stainless Cover	CE321150	CE321154	CE321157	CE321160

**Note:** Replacement EDL drain pans include electric heater rods.  
EDL pans are not available ( N / A ) on 3 Fan Long and 4 Fan units.  
Replacement Hot Gas drain pans do not include companion flanges, new gaskets, bolts, or nuts for the hot gas interpipng connections.  
Water Defrost with insulation can be fabricated with fiberglass. Contact factory.

**Table 11 REPLACEMENT DRAIN PANS (continued)**

<b>DRAIN PAN TYPE</b>	<b>3 FAN SHORT SECTION (50, 55, 60, 70, 74, 79)</b>	<b>3 FAN LONG SECTION (58, 65, 72, 84, 90, 96)</b>	<b>4 FAN SECTION ( 68, 75, 82, 95, 103, 110 )</b>
Drain Pan Dimensions	23.5" x 193"	23.5" x 229"	23.5" x 257"
Aluminum (Air, HGC, ED) Non-Insulated	CE320594	CE320209	CE320210
Aluminum (Air, HGC, ED) Insulated-Galv. Cover	CE320586	CE320205	CE320206
Aluminum (Air, HGC, ED) Insulated-Stainless Cover	CE321166	CE321170	CE321174
Aluminum (230V - EDL) Insulated – Galv. Cover	CE320724	N / A	N / A
Aluminum (460V - EDL) Insulated – Galv. Cover	CE320725	N / A	N / A
Aluminum (575V - EDL) Insulated – Galv. Cover	CE321398	N / A	N / A
Aluminum (380V - EDL) Insulated – Galv. Cover	CE321399	N / A	N / A
Aluminum (230V - EDL) Insulated – Stainless Cover	CE303866	N / A	N / A
Aluminum (460V - EDL) Insulated – Stainless Cover	CE303867	N / A	N / A
Aluminum (575V - EDL) Insulated – Stainless Cover	CE321400	N / A	N / A
Aluminum (380V - EDL) Insulated – Stainless Cover	CE321401	N / A	N / A
Aluminum (WD) Non-Insulated	CE320595	CE320420	CE320597
Stainless Steel (WD) Non-Insulated	CE231406	CE231407	CE231408
Stainless Waffle (HGP/HGS) Insulated-Galv. Cover	CE320583	CE320011	CE320012
Stainless Waffle (HGP/HGS) Insulated-Stainless Cover	CE321164	CE321168	CE321172

**Note:** Replacement EDL drain pans include electric heater rods.  
EDL pans are not available ( N / A ) on 3 Fan Long and 4 Fan units.  
Replacement Hot Gas drain pans do not include companion flanges, new gaskets, bolts, or nuts for the hot gas interpiping connections.  
Water Defrost with insulation can be fabricated with fiberglass. Contact factory.



**11 MAINTENANCE DATA**

<b>Date Performed</b>	<b>Drain Pan Inspection &amp; Cleaning</b>	<b>Cabinet and Coil Inspection &amp; Cleaning</b>	<b>Motor Inspection</b>	<b>Fan Inspection</b>	<b>Electric Heater Inspection</b>	<b>Water Defrost Pan Inspection</b>

# NOTES



