

UNIT SHOWN IN SHIPPING POSITION.
 UNIT HAS TO BE RAISED & SUPPORTED,
 LEGS UNBOLTED, LOWERED TO
 MOUNTING POSITION & REBOLTED.

NOTE: DIMENSIONAL DRAWING FOR QUOTATION
 PURPOSES ONLY. DO NOT USE FOR
 CONSTRUCTION DRAWING RELEASE NO.
 QC00001.

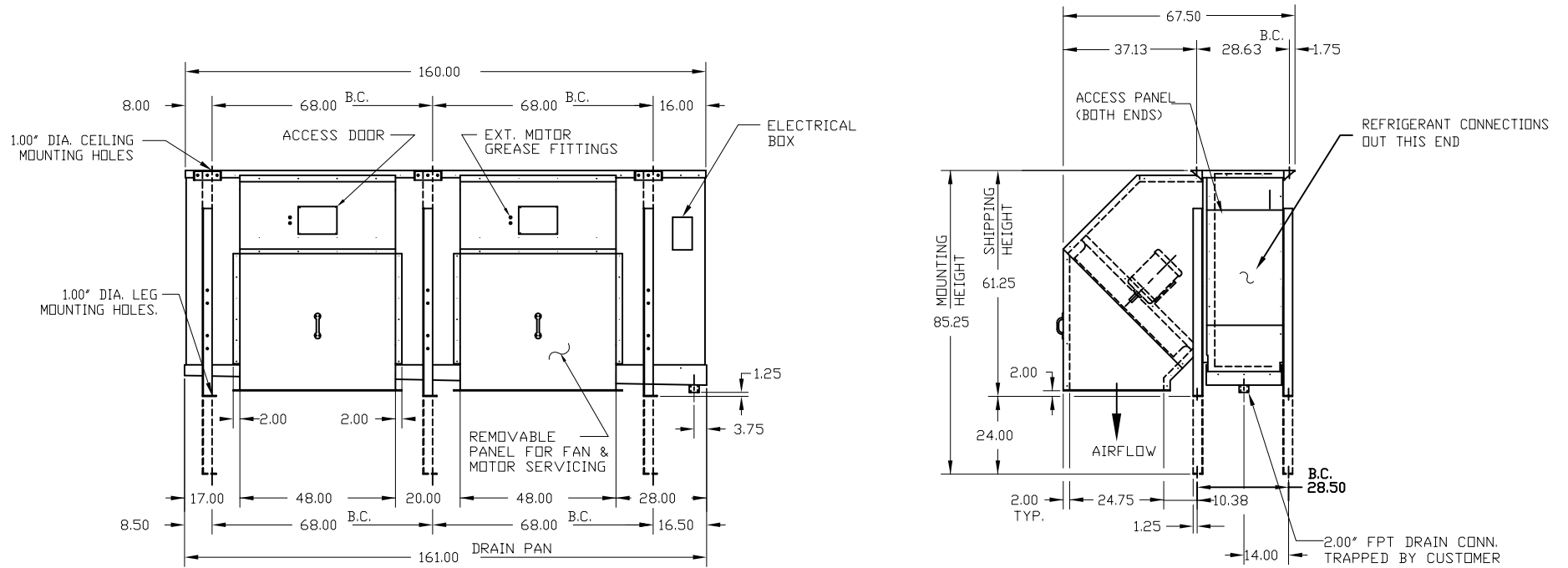

DESIGN SPECIFICATIONS	UNITS
UNIT COOLING CAPACITY	BTUH
ROOM TEMPERATURE	°F
SUCTION TEMPERATURE	°F
REFRIGERANT	-
*LIQUID FEED RATE	GPM
AIR FLOW RATE	CFM
EXTERNAL STATIC PRESSURE	INWG
NOMINAL FIN SPACING	FINS/IN
TOTAL SURFACE AREA	SQ FT
APPROXIMATE WEIGHT	LBS
COIL INTERNAL VOLUME	CU FT
*NOTE: LIQUID FEED PRESSURE MUST BE AT LEAST 5 PSIG ABOVE SUCTION PRESSURE.	

WORK TO DIMENSIONS
 DO NOT SCALE DRAWING

SALES ORDER	LINE	NO.	CHANGE DESCRIPTION	DATE	CK'D
CUSTOMER					
P.O. #					
CUSTOMER NAME	REVISIONS				
JOB NAME					
TAG UNIT					
MODEL	PH 2 -48 - - - - -RH				
ITEM NO.					
NO. REQ'D	DATE	12/01/04	DRAWN		
SHEET	<div style="text-align: center;"> KRACK CORPORATION </div>				REV.
TOLERANCE:					±0.50"